



SARS-CoV-2 Rapid Antigen Test Nasal

**Convenient sampling,
quick results**



Introducing the SARS-CoV-2 Rapid Antigen Test Nasal

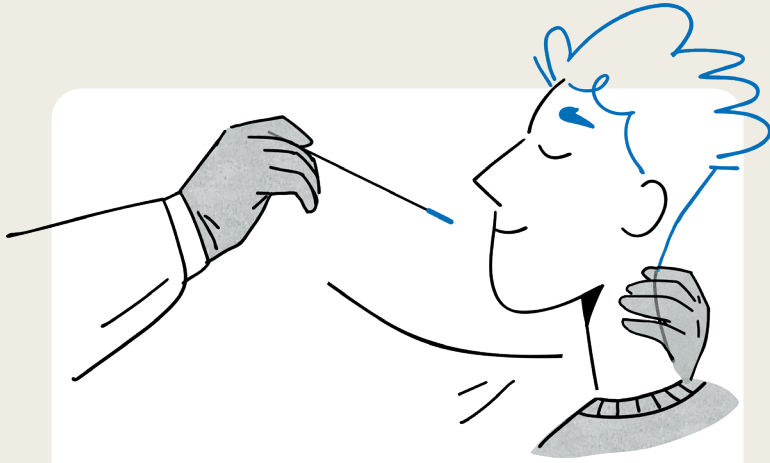

Nasal swab sample collection

89.6 %
(Ct ≤ 30)

Sensitivity¹

99.1 %

Specificity¹

Convenient sampling,
quick results



Decreased risk of exposure for healthcare professionals

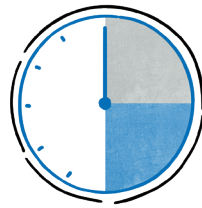

15 - 30

Results after 15 min

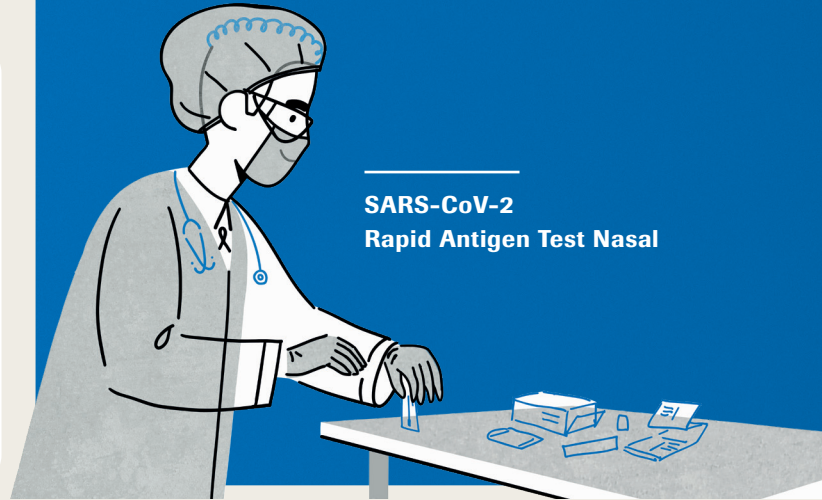

SARS-CoV-2 Rapid Antigen Test Nasal



Pre-filled tubes

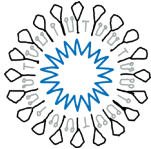

Target antigen
Nucleocapsid (N)

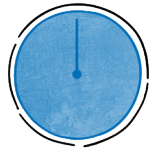

60

Test stability
1 hour after opened pouch



Self-collection possible
under supervision of a healthcare worker

*Less invasive
point-of-care
testing with
increased
protection for
healthcare
professionals*



No instruments needed

Key benefit



**Shelf life: 24 months
after manufacturing date**

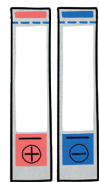

**1 × positive and negative QC
included in the kit**

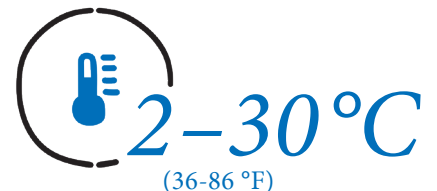

**Storage
temperature**

Cross-reactivity

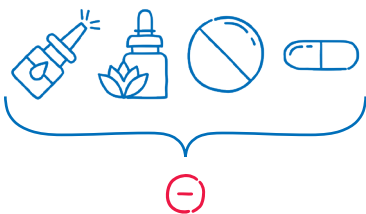

54 human-pathogenic specimens
tested negative for cross-reactivity.*
15 potential substances
tested negative for interference.

Test description

The SARS-CoV-2 Rapid Antigen Test Nasal is a rapid chromatographic immunoassay for the qualitative detection of SARS-CoV-2 nucleocapsid antigen present in human nasal samples.

This assay is intended to detect antigen from SARS-CoV-2 in individuals suspected of COVID-19 or with known or suspected exposure to SARS-CoV-2. The test is intended for professional use in laboratory and point-of-care environments, or self-collection under the supervision of a healthcare worker.



*Cross-reactivity is possible with human coronavirus HKU1 (31.6% homology), *Pneumocystis jirovecii* (PJP) (12.3% homology) and *Mycobacterium tuberculosis* (TB) (13.0% homology).

Testing procedure

Performing a test in 4 easy steps

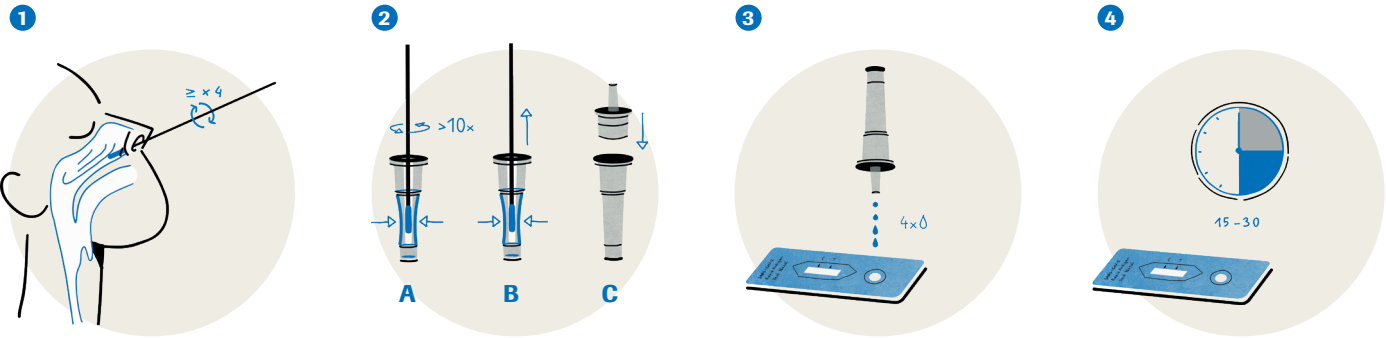

Nasal swab collection

Insert a sterile swab 2 cm into the patient's nostril with the most secretion. Rotate the swab 4 times for about 15 seconds against the nasal wall. Remove it from the nostril. Repeat procedure with the same swab in the other nostril.

Prepare the sample

- A** Insert the swab into an extraction buffer tube, squeeze the tube and stir the swab >10×.
- B** Remove the swab while squeezing the sides of the tube.
- C** Press the nozzle cap tightly onto the tube.

Drop of sample

Add 4 drops of extracted sample to the specimen well of the test device.

Read the test result in 15–30 min



Do not read test result after 30 minutes.

Quick and easy to read

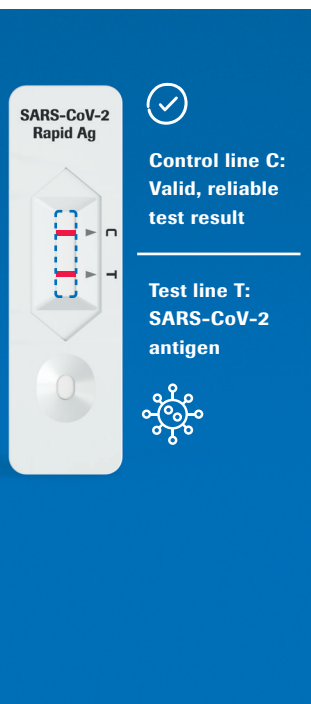

Positive

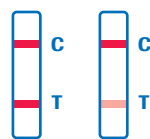

Individual has SARS-CoV-2 antigen present indicating active infection.

Positive results should not be used as the sole basis for treatment or patient management decisions, and should be considered in the context of the patient's recent exposures, history and the presence of clinical signs and symptoms consistent with COVID-19.



Negative



No SARS-CoV-2 antigen detected.

A negative test result does not eliminate the possibility of SARS-CoV-2 infection, and should be confirmed by viral culture or a molecular assay or ELISA if necessary for patient management.



Invalid

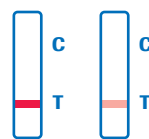

Result not valid Repeat with a new test.

Performance compared to PCR tests

Direct detection of the virus – through nucleic acid and antigen testing – is essential to contain the virus and make further treatment as well as quarantine decisions.

PCR tests are intended for the qualitative detection of SARS-CoV-2 in nasopharyngeal and oropharyngeal swab samples from patients.²

Rapid antigen tests detect the presence of a specific viral protein. A positive result requires a higher viral load than a PCR test for reliable antigen detection and a high test performance.

Centers for Disease Control and Prevention (CDC) recommend rapid antigen testing as diagnostic testing of individuals suspected of COVID-19 or with known or suspected exposure to SARS-CoV-2. (e.g. via contract tracing tools). The World Health Organisation (WHO) recommends screening of asymptomatic environments (institutions, care-homes, schools etc.) where PCR is not immediately available.^{3,4,5}

Both institutions recommend antigen testing within 5–7 days post symptom onset as during that time viral load is highest.^{3,4,5}

PCR tests are considered the gold standard due to the highest analytical sensitivity on the market. However, SARS-CoV-2 rapid antigen tests support to trace infectious individuals in decentralized locations, especially when lab testing isn't available and time is of the essence.

Clinical Sensitivity of a Rapid Test compared to PCR⁶

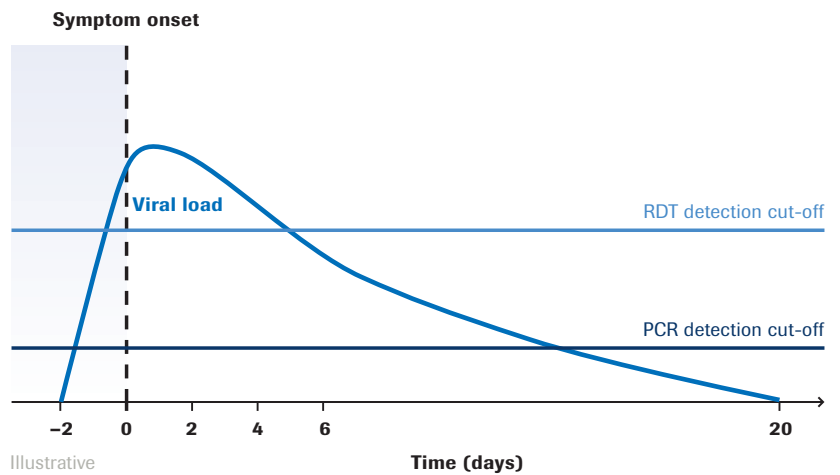

Structure of the Severe Acute Respiratory Syndrome Coronavirus 2 (SARS-CoV-2)⁷

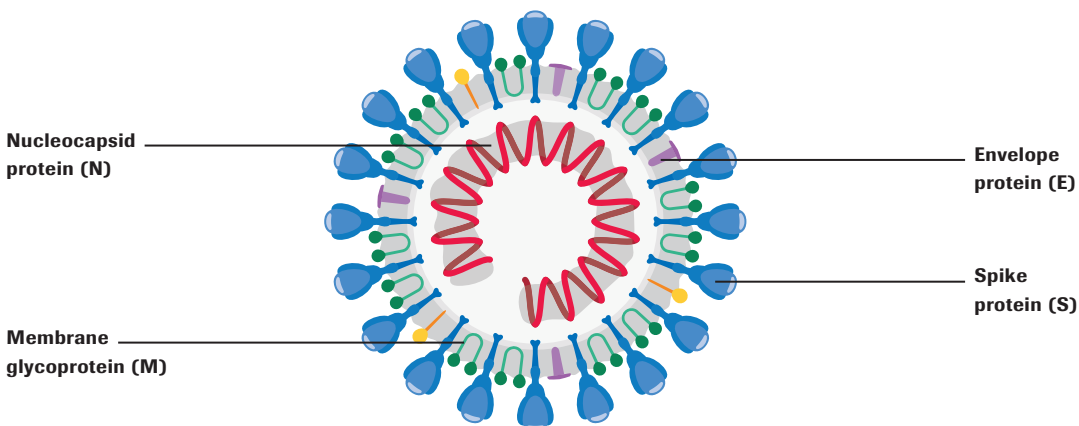

Summary of sample characteristics¹

	Overall	HCP collection	Self-collection
N	696	311	385
Asymptomatic, n/N (%)	20/696 (2.9 %)	7/311 (2.3 %)	13 / 385 (3.4 %)
Symptomatic, n/N (%)	676/696 (97.1 %)	304/311 (97.7 %)	372 / 385 (96.6 %)
DPSO, median (range)	3 (0 – 27)	3 (0 – 15)	4 (0 – 27)
PCR positive, n/N (%)	150/696 (21.6 %)	77/311 (24.8 %)	73 / 385 (19.0 %)
PCR positive symptomatic, n/N (%)	147 / 150 (98.0 %)	75 / 77 (97.4 %)	72 / 73 (98.6 %)
PCR positive asymptomatic, n/N (%)	3 / 150 (2.0 %)	2 / 77 (2.6 %)	1 / 73 (1.4 %)
PCR negative, n/N	546 / 696 (78.4 %)	234 / 311 (75.2 %)	312 / 385 (81.0 %)
PCR sample type	Combined OP/NP	Combined OP/NP	Combined OP/NP

Performance overview¹

For professionally collected samples, the test was found to have a sensitivity of 89.6 % (Ct ≤ 30) and a specificity of 99.1 %.^{***}

Sensitivity	Professional collection	Self-collection	Limit of detection SARS-CoV-2 (2019-nCoV) NCCP 43326/2020
Ct ≤ 24 , (95 % CI), N	97.7 % (88.0 % – 99.9 %), 44	97.9 % (88.7 % – 99.9 %), 47	
Ct ≤ 27 , (95 % CI), N	93.1 % (83.3 % – 98.1 %), 58	94.7 % (85.4 % – 98.9 %), 57	
Ct ≤ 30 , (95 % CI), N	89.6 % (79.7 % – 95.7 %), 67	89.1 % (78.8 % – 95.5 %), 64	Concentration 9.25 × 10 ^{1.2} TCID ₅₀ /mL
Ct ≤ 33 , (95 % CI), N	87.1 % (77.0 % – 93.9 %), 70	84.5 % (74.0 % – 92.0 %), 71	
All Ct values , (95 % CI), N	83.1 % (72.9 % – 90.7 %), 77	82.2 % (71.5 % – 90.2 %), 73	
Specificity			
All Ct values , (95 % CI), N	99.1 % (96.9 % – 99.9 %), 234	99.0 % (97.2 % – 99.8 %), 312	

^{***}Vs. comparator RT-PCR: Roche cobas® SARS-CoV-2 and TibMolbiol SARS-CoV-2 E-gene assay.

Your kit for convenient sampling with quick results

- Results in 15 – 30 minutes
- Less invasive and more convenient testing
- Increased protection for healthcare workers

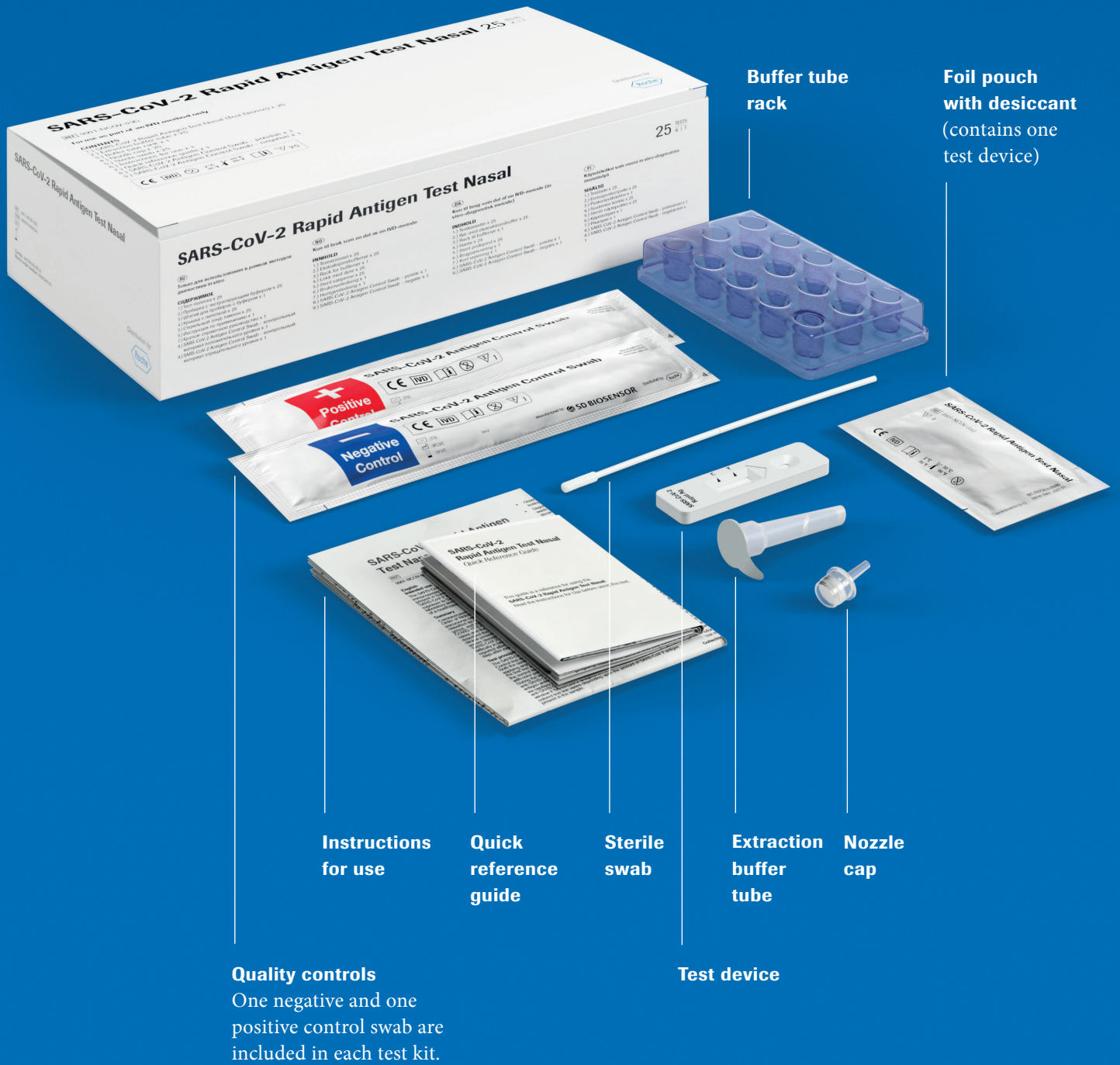

Ordering information

Product	REF #	GTIN	Cat #	Roche Material #	PZN (DE only)
Languages 1 – 8: Spanish, Portuguese, German, French, Italian, Dutch, Swedish, Turkish					
SARS-CoV-2 Rapid Antigen Test Nasal	9901-NCOV-03G	08809319398233	99COV33D-ML01	09365397023	1173555
Languages 9 – 16: English (CE), Hungarian, Czech, Polish, Russian, Norwegian, Danish, Finnish					
SARS-CoV-2 Rapid Antigen Test Nasal	9901-NCOV-03G	08809319398240	99COV33D-ML02	09365397043	/

References

- 1 SARS-CoV-2 Rapid Antigen Test Nasal Method Sheet (V2, April 2021).
- 2 Wölfel, R. et al. (2020). *Virological assessment of hospitalized patients with COVID-2019* 581 (7809), 465 – 469.
- 3 CDC. <https://www.cdc.gov/coronavirus/2019-nCoV/hcp/clinical-criteria.html>.
- 4 Criteria to Guide Evaluation and Laboratory Testing for COVID-19.
Available at: <https://www.cdc.gov/coronavirus/2019-nCoV/hcp/clinical-criteria.html>. Accessed Sept 11, 2020.
- 5 COVID-19 (Rapid) Antigen Testing Recommendations WHO update September 11th 2020.
Available at: <https://www.who.int/emergencies/diseases/novel-coronavirus-2019/technical-guidance-publications?publicationtypes=f85a3610-b102-4287-a6df-f3bc0b2e9f7c>.
- 6 Huang, C et al. (2020). *Lancet* 395, 497-506.
- 7 Masters PS (2006). *Advances in Virus Research. Academic Press.* 6

Published by

Roche Diagnostics NZ Ltd
ANZ Raranga Building, Level 1, Sylvia Park
286 Mount Wellington Highway
Mount Wellington, Auckland 1060
New Zealand

© 2021

All trademarks mentioned enjoy legal protection.

diagnostics.roche.com